

EDDYSTONE

MARINE RECEIVER MODEL 670C INSTRUCTION MANUAL

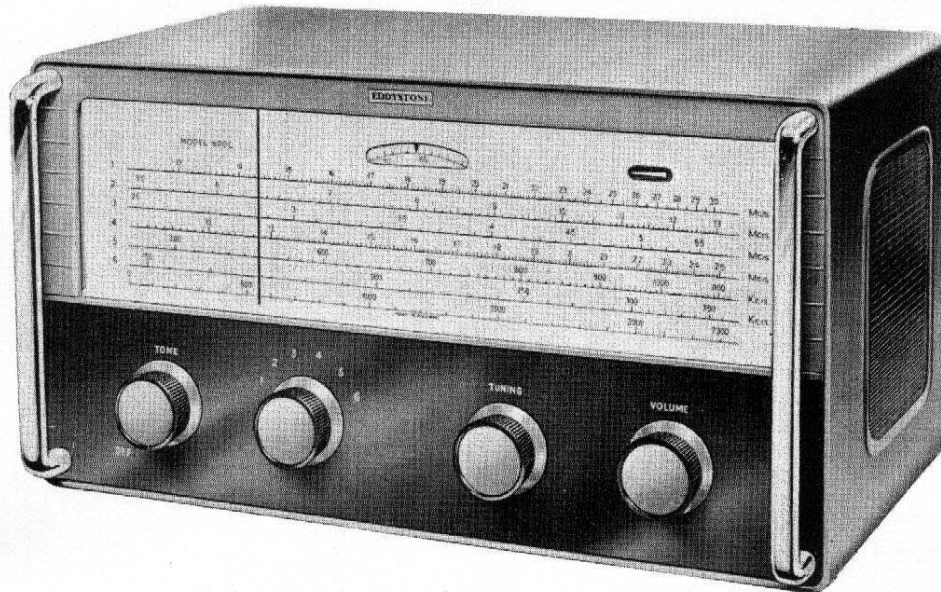

The EDDYSTONE Model 670C is a six-valve superhet receiver covering the long, medium and short-wave bands in the frequency ranges 150 to 350 kc/s and 500 kc/s to 30 Mc/s. It is primarily intended for cabin use in sea-going vessels but is equally suited to any application calling for a receiver with a performance superior to that obtained with the average domestic type. Any standard AC or DC mains supply can be used to power the "670C" and where such supplies are not available it is possible to operate from an accumulator in conjunction with a suitable transistorised power supply. An efficient filter circuit cuts out most types of mains-borne interference.

The receiver is easy to use and the functions of the four controls (tuning, wavechange, volume and tone/on-off) are clearly marked. The tuning control has a reduction ratio of the order 140 : 1 and provides the extremely "fine" adjustment called for in tuning stations on the short-wave ranges. Flywheel loading permits rapid change of frequency when required and the drive will be found extremely smooth and free from backlash. The wide frequency scales can be read with ease and a special "logging" system allows accurate dial settings to be recorded for future use. All Amateur and Broadcast bands are clearly marked and precise tuning is assured by use of the visual tuning indicator at the right-hand side of the dial.

A built-in loudspeaker is fitted, but where an external unit is preferred this can be connected in lieu. As an alternative to speaker reception, telephones can be used and this facility will no doubt be found useful in many applications. If desired, the "670C" can be used as an amplifier for a "gram" unit; connection is to a socket at the rear and the volume and tone controls operate exactly as during normal reception.

Advanced design, rugged construction and high quality components are used throughout; the receiver is of a most convenient size, contemporary in appearance and being housed in a strong metal cabinet will stand up well to frequent transportation. Continuous operation is possible in all parts of the world and special attention has been given to the safety precautions called for in British Standard BS.415.

The complete frequency coverage is divided into six ranges as follows :

| | | |
|---------|-------|------------------|
| Range 1 | | 13.0 — 30.0 Mc/s |
| Range 2 | | 5.5 — 13.0 Mc/s |
| Range 3 | | 2.5 — 5.5 Mc/s |
| Range 4 | | 1.11 — 2.5 Mc/s |
| Range 5 | | 500 — 1110 kc/s |
| Range 6 | | 150 — 350 kc/s |

INSTALLATION

Mains Voltage Adjustment

The receiver can be operated equally well from either AC or DC mains supplies. No adjustment is necessary when changing from AC to DC but it is important to check that the voltage selector at the rear of the receiver is set to suit the local mains voltage before making connection to the supply.

When despatched from the factory, the selector is placed in the 230V position which is correct for operation from mains voltages in the range 225—250V. If the local mains supply is between 200—225V the selector plug should be withdrawn from the 230V socket and plugged into the 200V position. The 110V socket is suitable for mains supplies in the range 100—125V.

Mains Connections and Earthing

The mains input is taken via a small plug and socket at the rear of the cabinet, the plug being ready wired with six feet of three-core mains cable. One end of the cable is left free so that the user can fit a plug of a type suitable for connection to the local mains supply. If the existing lead proves too short, it can be easily disconnected from the plug and replaced by a longer length. In most cases the existing lead will be adequate and this is coded as follows :

Red : Live (Positive DC), Black : Neutral (Negative DC), Green : Earth.

The plug for connection to the local mains supply may be either a two-pin or a three-pin type. In the case of the latter, the green lead is connected to the thicker of the three pins but with a two-pin plug this lead should be cut off short and then pressed back into the cable covering so that there is no chance of it shorting to the other leads. When using a plug of this type, it is still essential that an earth connection is made to the receiver and the socket marked 'E' is intended primarily for this purpose. In some cases, when the earth is via a standard three-pin plug, socket 'E' can be used to connect an additional earth to give improved reception. In either case the earth connection should be as short and direct as possible and should be made with fairly heavy gauge insulated wire terminated in the small plug provided with the receiver.

When the earth is made by a three-pin mains plug, the small plug supplied for connection to socket 'E' should be left in position (although unwired) to complete the earth to the internal chassis. The effect of this is to improve reception and mains noises which may be evident with the plug disconnected will usually disappear when the plug is in place.

It is strongly recommended that in the interest of safety the receiver is always operated with an earth connection. If operation should at any time be without an earth, the plug must be removed from socket 'E.'

On AC supplies when a three-pin plug is used, the red lead should be connected to the pin that engages with the right-hand socket of the wall fitting. This is true on the assumption that the wall fitting is wired correctly but if as is sometimes the case the fitting is wired incorrectly, it may be found that an objectionable hum appears in the output from the receiver. Reversing the red and black connections to the plug will remove the hum.

Two-pin AC plugs should be reversed if a hum is present and can then be marked to indicate the correct orientation.

On DC, the receiver will function only if the polarity of the supply is correct. Thus, if the set fails to operate after the normal warming-up period, reversal of the plug will clear the trouble.

When using an accumulator and transistor converter, advice on the correct method of connection should be sought from the supplier of the unit. As a general rule, treat the output from the converter as a normal mains supply and make voltage adjustments and connections as appropriate. For example, in connecting a transistor converter whose output is 250V DC, the voltage adjuster (receiver) should be set to 230V and it will be necessary to ensure correct polarity of the connection to the converter. Remember that the positive connection is the red wire in the lead from the receiver. A converter giving an output in the range 100/125V is preferred since this results in less current drain from the accumulator (1.5 — 2 Amps).

It should be noted that, when an accumulator is used in conjunction with a converter as described above, the on/off switch on the receiver will not switch off the accumulator current. In most cases the converter will have a switch for this purpose but if not, consult the supplier for advice on incorporating this facility.

The Aerial

The Model 670C is an extremely sensitive receiver and will give a good account of itself even on poor indoor aerials. When optimum reception is called for however, consideration should be given to provision of an outside aerial since the improved performance obtained will well repay the task of installing it. Such an aerial can be of any length up to 100 feet or so, well insulated and sited clear of all local obstructions especially those of a metallic nature. Aerials of this type are referred to as "single-wire" or "unbalanced" aerials and are connected at the right-hand socket labelled "A." A "shorting-plug" is provided with the receiver and this must be in position between the other "A" socket and earth (see inset drawing with circuit diagram).

For improved reception over restricted frequency bands (or when local noise is a problem, a dipole aerial cut to the correct length for the frequency required is probably the most suitable arrangement. Aerials of this type have a "T" formation with a twin balanced feeder which helps reduce noise pick-up on the lead-in. The feeder wires are connected separately to the two "A" sockets and the "shorting-plug" is removed when using this type of aerial.

A big advantage of the dipole is that the feeder can be of any length so allowing the aerial proper (the top portion of the "T") to be placed in the most suitable position. The feeder can be run close to obstructions without any adverse effect on the performance of the system.

One disadvantage of the dipole is that performance is only optimum over the band for which it is designed. Typical dimensions are given in the Table below, while for other bands the overall length can be calculated by dividing 468 by the frequency in Mc/s. The result will be in feet.

Broadcast

| | | | | | | | |
|---------------|-----|-----|------|------|------|------|----|
| Band (Metres) | 49 | 31 | 25 | 19 | 16 | 13 | 11 |
| Freq. (Mc/s) | 6.1 | 9.6 | 11.8 | 15.1 | 17.8 | 21.5 | 26 |
| Length (ft.) | 76 | 48 | 39 | 30 | 26 | 21 | 18 |

Amateur

| | | | | | | |
|---------------|-----|-----|----|----|----|------|
| Band (Metres) | 160 | 80 | 40 | 20 | 15 | 10 |
| Freq. (Mc/s) | 1.8 | 3.5 | 7 | 14 | 21 | 28 |
| Length (ft.) | 264 | 132 | 66 | 33 | 22 | 16.5 |

On frequencies for which the dipole is not designed, improved results can sometimes be obtained by strapping the two feeder wires together to make a "T" aerial. Connection is as for the single-wire aerial with the shorting-plug in place.

More detailed advice on aerials will be found in the booklet "Better Radio Reception" which is supplied with this receiver.

Connecting an External Loudspeaker

An external loudspeaker can be connected after taking out the internal speaker plugs at the rear of the set (labelled LS — 2.5 ohms). The volume control should be turned down whilst making the connections and the external speaker should be fed with standard twisted flex terminated with suitable plugs. No transformer is required and the speaker should be a standard 2.5/3 ohm type. Both speakers can be operated simultaneously if their leads are connected in parallel but there will be some drop in the volume level of each speaker. Telephones are connected in the same way as the external speaker and both this and the internal unit should be disconnected when using 'phones. Low impedance telephones will give the best results.

Connecting a Pick-up

Any medium or high impedance "gram" pick-up can be connected directly to the pick-up socket (P.U.) at the rear of the set. A low impedance pick-up can be used if a suitable matching transformer is employed.

Connection is with a standard jack plug (preferably of the screened type) using screened cable, the braid of which is connected to the sleeve of the plug.

OPERATION

Assuming that the mains supply is "on" at the wall socket, the receiver is brought into operation by rotating the tone control in a clockwise direction away from the "off" marking on the finger plate. An audible click will be heard, indicating that the switch has moved to the "on" position. Initially, the exact setting of the tone control is of no importance since it will be adjusted for the desired tone when the wanted station has been tuned in. After a short warming-up period the receiver will

become operative and this will be indicated by the glow of the visual tuning indicator. Adjust the volume control to give a convenient output from the speaker.

To tune to a specific frequency, determine the range on which the frequency lies by referring to the figures at the left-hand end of the scales. Set the wavechange switch to the appropriate position and then move the tuning pointer to the correct setting by means of the tuning control. The visual tuning indicator is used to make the final precise adjustment of this control, the receiver being correctly tuned when the illuminated line on the indicator contracts to the shortest length. Final adjustments can now be made to the tone and volume controls.

It will be noticed that the dial calibration is in terms of frequency rather than in wavelength. This is a big advantage especially on the short-wave ranges since the published frequencies for stations using these bands are precise whereas the wavelengths quoted are often approximate. As a result of this stations can be selected more rapidly by using frequencies when tuning. All broadcast bands are marked in red and amateur allocations in black.

If the wavelength but not the frequency of a station is known, the latter can be determined quite easily by making a simple calculation. Dividing 300 by the wavelength will give the frequency in megacycles. For example, a station on 100 metres would appear on a frequency of 3 Mc/s, one on 50 metres at 6 Mc/s and so on. On the lower wavelengths, frequencies are quoted in kilocycles (1 Mc/s = 1000 kc/s) and in this case it is only necessary to multiply the figure in megacycles by 1000 to obtain the frequency directly in kilocycles; 0.5 Mc/s for example, would be 500 kc/s.

In addition to the frequency scales, there is a further scale on the main dial which is calibrated in arbitrary divisions 0-2300. This scale is used in conjunction with the vernier scale (top centre of main dial) to obtain very accurate dial settings for specific stations. These selected stations can then be tuned in more rapidly than would otherwise be the case. The readings on the horizontal and vernier scales are combined to give a one, two, three or four figure number which corresponds to the frequency setting in use. A list of dial settings can be compiled for future use in tuning to preferred stations.

SERVICING INSTRUCTIONS

CAUTION. The Model 670C is a universal type and great care should be taken when carrying out tests with the cabinet removed. When running from AC supplies it is advisable to ensure that the chassis is connected to the neutral pole of the supply. If an isolation transformer is available this will be found more convenient and can probably be operated at an output voltage of 110V as a further safety precaution.

Should the receiver fail in operation, first check that all external connections are made correctly and also that mains voltage is available at the supply point. Next check the fuses. These are located in insulated holders at the rear of the receiver and are easily removed without risk of electric shock. Visual inspection will reveal whether or not a fuse has blown. Replacements should be standard 1½" cartridge types rated at 500mA (½ Amp.). If a blown fuse is changed and the replacement burns out immediately or after a very short period of operation, it is an indication that some internal component is faulty. In this case the receiver should be taken to the nearest EDDYSTONE Agent who will rectify the trouble at a reasonable charge.

If it is necessary to take the receiver to an engineer who is not familiar with Eddystone equipment, take this instruction sheet with the set. It contains information which may enable him to clear the fault more rapidly than would otherwise be the case.

Circuit Description

The Model 670C is a 6-valve receiver and can be used on all AC/DC mains supplies in the ranges 100/125V and 200/250V. Alternatively a 6, 12 or 24V accumulator can be used provided that a suitable transistorised converter is available giving an AC or DC output in the ranges quoted above. Current requirement is of the order 150mA and lowest battery drain will obtain when a unit delivering a voltage in the range 100/125V is used. In this case approximately 1.5-2A would be drawn from a 12V accumulator.

The single-conversion circuit features a tuned RF Amplifier (V1) which uses a high gain pentode type UAF42. The diode in this valve is used to protect the input circuits in the event of operation close to a high powered transmitter, a situation likely to be met on board ship. Protection against static build-up on the aerial

is provided by the two "static-leaks" R1 and R2 across the receiver input.

A UCH42 triode-hexode is employed in the Frequency Changer Stage (V2) in which the triode portion functions as a tuned-grid oscillator. Ganged tuning is used in conjunction with a switched six-range coil unit comprising eighteen precision wound inductors. The IF output from the Frequency Changer is at 450 kc/s and a single stage of amplification is provided at this frequency. Two permeability-tuned transformers provide excellent selectivity and the IF valve is a UAF42 (V3).

The diode in the IF valve envelope is used as the AGC Rectifier and controls the RF, IF and Mixer Stages on Ranges 3-6 while on Ranges 1 and 2 the RF and IF Stages only are controlled to prevent oscillator pulling. The visual tuning indicator (V4:DM70) is also controlled by the AGC valve.

V5 is another UAF42 and combines the functions of Signal Detector and 1st Audio Amplifier. The detector is a series diode type and its output is taken via the normally closed contact on the pick-up socket to the volume control which feeds the pentode portion of the valve. The contact mentioned above is opened automatically when a plug is inserted to allow connection of the gram pick-up and in this way interference from signals is prevented while records are being played. The pentode portion of V5 is resistance-capacity coupled to the following stage (V6) which is a UL41 and serves as the Audio Output Stage. Negative feedback is applied and tone control is by means of the variable resistor (RV2) across the primary of the output transformer. The power supply circuitry is quite conventional and employs a silicon diode (D1:DD058) as a half-wave rectifier for AC operation. A thermistor (R36) is included in the series connected heater chain to reduce the current surge at "switch-on" and this device prolongs the life of the valves used in the receiver. No indicator lamp is fitted since this function is effectively performed by the visual tuning indicator which exhibits a green glow when the receiver is operative.

Valve Replacement

All the valves used in the Model 670C are easily accessible when the cabinet is removed. All except the tuning indicator have B8A bases. The pins on these bases are equally spaced and correct location of the valve in relation to the holder is achieved by means of a small glass pip on the side of the envelope base. This locates with a retaining slot on the side of the base fitting. Care should be exercised in removing and replacing valves not to exert any sideways strain since this could result in fracture of the glass envelope.

The visual tuning indicator has a miniature B8D base and is retained in a small metal clip. The indicator can be removed by sliding it out of the clip after freeing it from the base.

When fitting a replacement indicator it will be necessary to trim the four long lead-out wires to the same length as the four shorter ones. The leads should be carefully straightened to line up with the sockets so that the indicator can be plugged into its base. When sliding back into the clip, make sure that the "keyhole" in the indicator lines up with the aperture in the scale plate.

Pointer Drive Cord Replacement

In the unlikely event of the drive cord either breaking or slipping out of the pulley grooves, replacement will be much simplified (even when the original cord is undamaged) if a new length is obtained. This can be made longer than the length actually required (3' 8½") and will therefore be easier to handle. Replacement will present no problems if the instructions given below are followed carefully.

NOTE: In these instructions, "left" and "right" are as viewed from the rear of the receiver.

1. Remove the cabinet after taking out the four retaining screws at the rear.
2. Take off the old drive cord by slackening the 8BA screws in the drive pulleys.
3. Set the tuning control so that the gang is fully meshed.
4. Secure one end of the replacement cord to the 8BA screw in the left-hand drive pulley (the screw should lie at approximately 2 o'clock).
5. Feed the cord through the pulley slot and into the groove nearest to the panel (cord leaving pulley from right to left).
6. Pass the cord below the tuning indicator, clockwise round the jockey pulley and across the dial between the pointer guide rods (cord passes under the pointer carrier).

7. Hold the free end of the cord in tension and rotate the tuning control to unmesh the gang. This operation will wind approximately three turns of drive cord onto the left-hand drive pulley.
8. Pass the cord clockwise round the guide pulley at the right-hand end of the pointer guide rods and then back across the dial towards the right-hand drive pulley.
9. At this stage, apply tension to the cord so that the sprung jockey pulley takes up a position slightly less than $\frac{1}{4}$ " inside the guide rod support bracket.
10. Maintain this tension and lay the cord in the second groove from the edge of the pulley nearest to the rear of the receiver. Feed the cord along the groove and into the pulley slot. Secure to the 8BA screw which should lie at about 10 o'clock. Check the jockey pulley position and then cut off the surplus cord.
11. Slide the pointer along the guide rod to the right-hand end and attach the cord to the carrier by sliding up under the spring. The spring can be depressed slightly if necessary.
12. Move the gang to the fully meshed position and set the pointer to "0" on the logging scale.
13. Check drive for free and normal operation and ensure that the vernier tracking is correct.
14. Check the dial calibration against a suitable frequency standard.
15. Replace cabinet and fit retaining screws.

Cleaning the Scale and Scale Window

1. Locate the three screws disposed vertically at each end of the rear of the scale plate. Take out the centre screw at each end and remove the small side castings at the extremities of the glass window.
2. Slacken the four countersunk screws along the top edge of the panel and slide out the white glass support strip.
3. The glass is now free and can be removed by lifting up and tilting back slightly.

Re-alignment — General

If a complete re-alignment is necessary the instructions below should be followed in full. When partial re-alignment is called for (to compensate for ageing components etc.), the relevant instructions can be extracted as required.

It must be stressed that alignment adjustments should not be tampered with unless there is a clear indication that re-alignment is in fact required. Adjustment should only be carried out by fully skilled technicians equipped with adequate test instruments.

Re-alignment of the IF Transformers

First disable the local oscillator by shorting out the forward section of the tuning gang (C35). Set the range switch to 5, tuning to 500 kc/s and the tone control to its fully clockwise position. The volume control should be at maximum, and the AGC line must be shorted to chassis. This connection is most conveniently made at the 1st IF transformer tag to which is wired the 6·8 megohm resistor R22 and the 0·01 mfd capacitor C57.

Connect the signal generator output leads via 0·01 mfd isolating capacitors to the mixer section of the tuning gang (C29). An output meter matched to 2·5/3 ohms should be connected to the loudspeaker sockets at the rear. The speaker can remain in circuit but must be disconnected when making sensitivity checks. Allow some 10 minutes for warming-up and then tune the signal generator to 450 kc/s with modulation at a depth of 30% (400 c/s). Adjust the attenuator for a convenient output and then peak the cores in T1 and T2 for maximum reading on the meter. It should be noted that each core will give two peaks and the correct one to use is the "inner" peak, i.e. the one that occurs when the core is closest to the opposite coil.

Increase the attenuation as alignment proceeds and ensure that on completion a sensitivity of at least 10 μ V is obtained for an output of 50mW. If this figure cannot be achieved, some improvement may be forthcoming if V3 is changed. Failing this, check the audio sensitivity by introducing a 1000 c/s signal at the P.U. socket. An input of 27mV at this point should provide an output of 50mW.

On completion of this phase of the alignment, remove the signal generator leads from the mixer section of the gang and also the short across the oscillator section. The shorting link disabling the AGC should be left in position.

RF Alignment

The first step in re-alignment of the RF Section of the receiver is a check on the accuracy of the dial calibration to ascertain whether adjustment is required in the oscillator stage. This check is best carried out by using a modulated crystal controlled harmonic generator since the accuracy of the average signal generator is less than the scale accuracy of the receiver (0·5%). The marker signal should be introduced at the aerial input and checks made at 100 kc/s intervals on the low frequency ranges and every 500 kc/s on the higher frequencies. If the indications are that calibration accuracy is outside the limit quoted, re-alignment of the oscillator tuned circuits will be required. Standard tracking procedure should be adopted using the alignment points and adjustments listed in the Table below :

| Range | Trimming Frequency | Trimmer | Padding Frequency | Core |
|-------|--------------------|---------|-------------------|------|
| 1 | 27·0 Mc/s | C38 | 13·5 Mc/s | L13 |
| 2 | 12·0 Mc/s | C40 | 6·0 Mc/s | L14 |
| 3 | 5·2 Mc/s | C43 | 2·7 Mc/s | L15 |
| 4 | 2·3 Mc/s | C46 | 1·15 Mc/s | L16 |
| 5 | 1000 kc/s | C49 | 500 kc/s | L17 |
| 6 | 320 kc/s | C52 | 160 kc/s | L18 |

The sequence of coil positions in the coil box is "Range 1 — 2 — 3 — 5 — 4 — 6" and care should be taken not to adjust the wrong circuits on Ranges 4 and 5. The ranges are marked on the coil box cover which must be in position while alignment is carried out. An insulated screwdriver is required for adjusting the dust cores and a Mullard trimming tool type TCT01 for the concentric trimmers.

The oscillator tracks "high" on all ranges. On Ranges 1 and 2 it may be possible to set the oscillator on the "low" side of the signal and a check should be made to ensure that the response with minimum capacity or minimum inductance is selected. The interaction between the trimming and padding adjustments should be carefully balanced out by repeating each adjustment at least twice.

Once the scale calibration has been checked and corrected if necessary, alignment of the RF and Mixer circuits can be commenced. The signal generator should be arranged to match 75 ohms on Ranges 1 — 4 and 400 ohms on Ranges 5 and 6. Connection is to the aerial input socket at the rear and blocking capacitors are not required in this instance. The attenuator setting should be such that overloading of the receiver does not

occur and adjustments are best made by observing the reading on the output meter connected to the speaker sockets at the rear of the set. Alignment adjustments are made at the following frequencies, tuning for maximum output with the appropriate trimmer or core. As with oscillator alignment, each adjustment should be repeated at least twice to reduce errors due to interaction. Remember that Ranges 4 and 5 do not run in sequence with the other ranges.

| Range | Trimming | | | Padding | | |
|-------|-----------|-----|-------|-----------|----|-------|
| | Freq. | RF | Mixer | Freq. | RF | Mixer |
| 1 | 27·0 Mc/s | C4 | C22 | 13·5 Mc/s | L1 | L7 |
| 2 | 12·0 Mc/s | C6 | C23 | 6·0 Mc/s | L2 | L8 |
| 3 | 5·2 Mc/s | C7 | C24 | 2·7 Mc/s | L3 | L9 |
| 4 | 2·3 Mc/s | C8 | C25 | 1·15 Mc/s | L4 | L10 |
| 5 | 1000 kc/s | C9 | C26 | 500 kc/s | L5 | L11 |
| 6 | 320 kc/s | C10 | C27 | 160 kc/s | L6 | L12 |



Printed in England

Manufacturers :
STRATTON & CO. LTD.
 ALVECHURCH ROAD, BIRMINGHAM, 31
 Telephone: PRIORITY 2231/4 Cables: STRATNOID, BIRMINGHAM



Telex: 33708

March, 1963

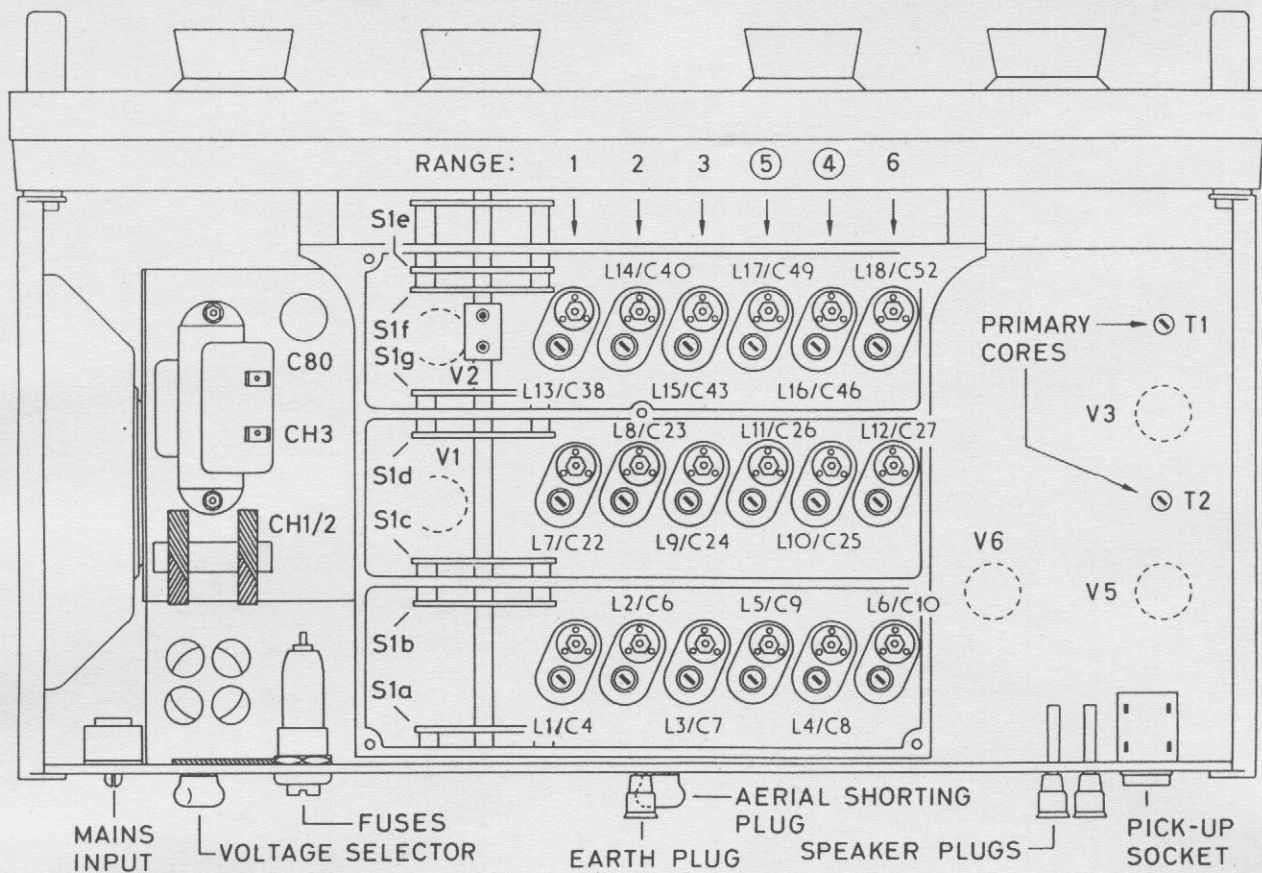

Underside view of receiver

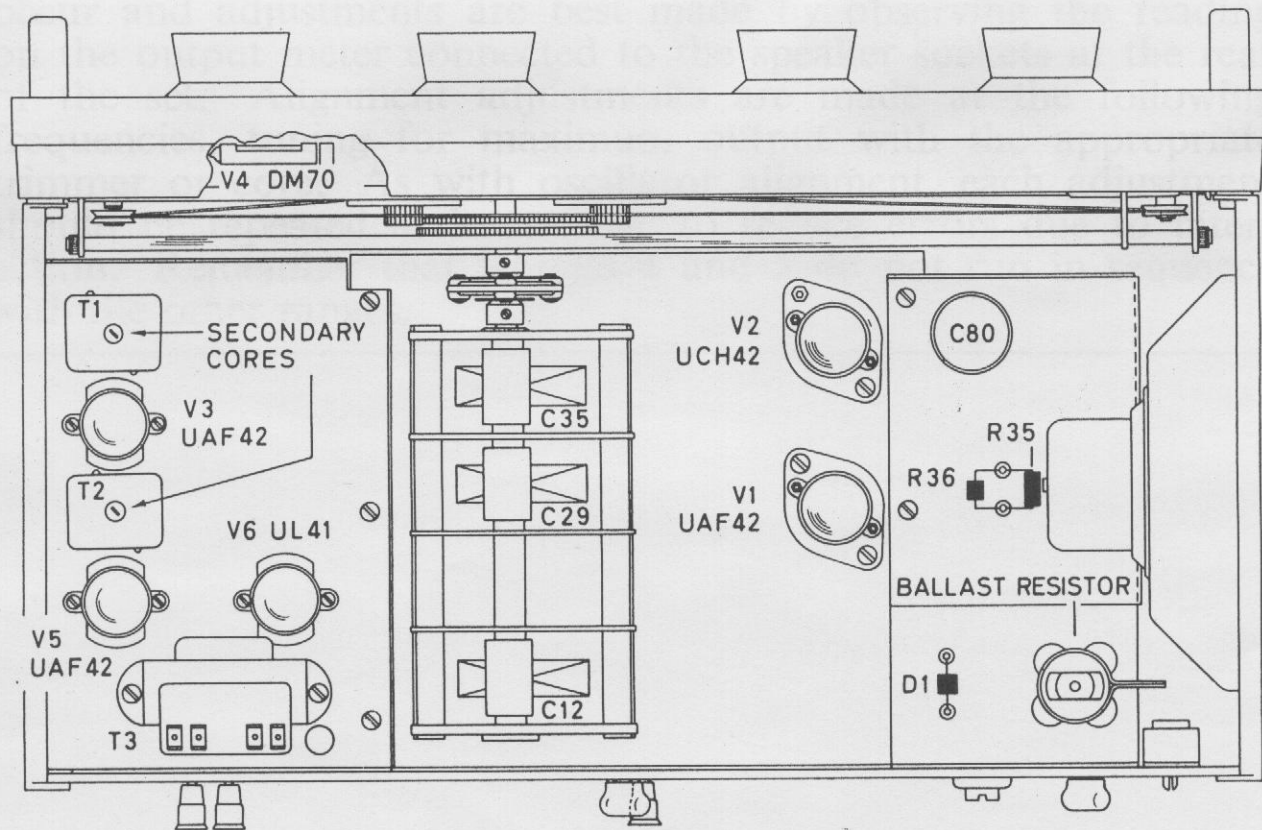

Plan view of receiver

11.
12.
13.
14.
15.
Cl
1.

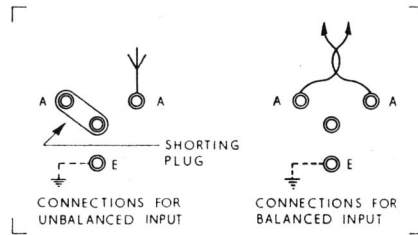
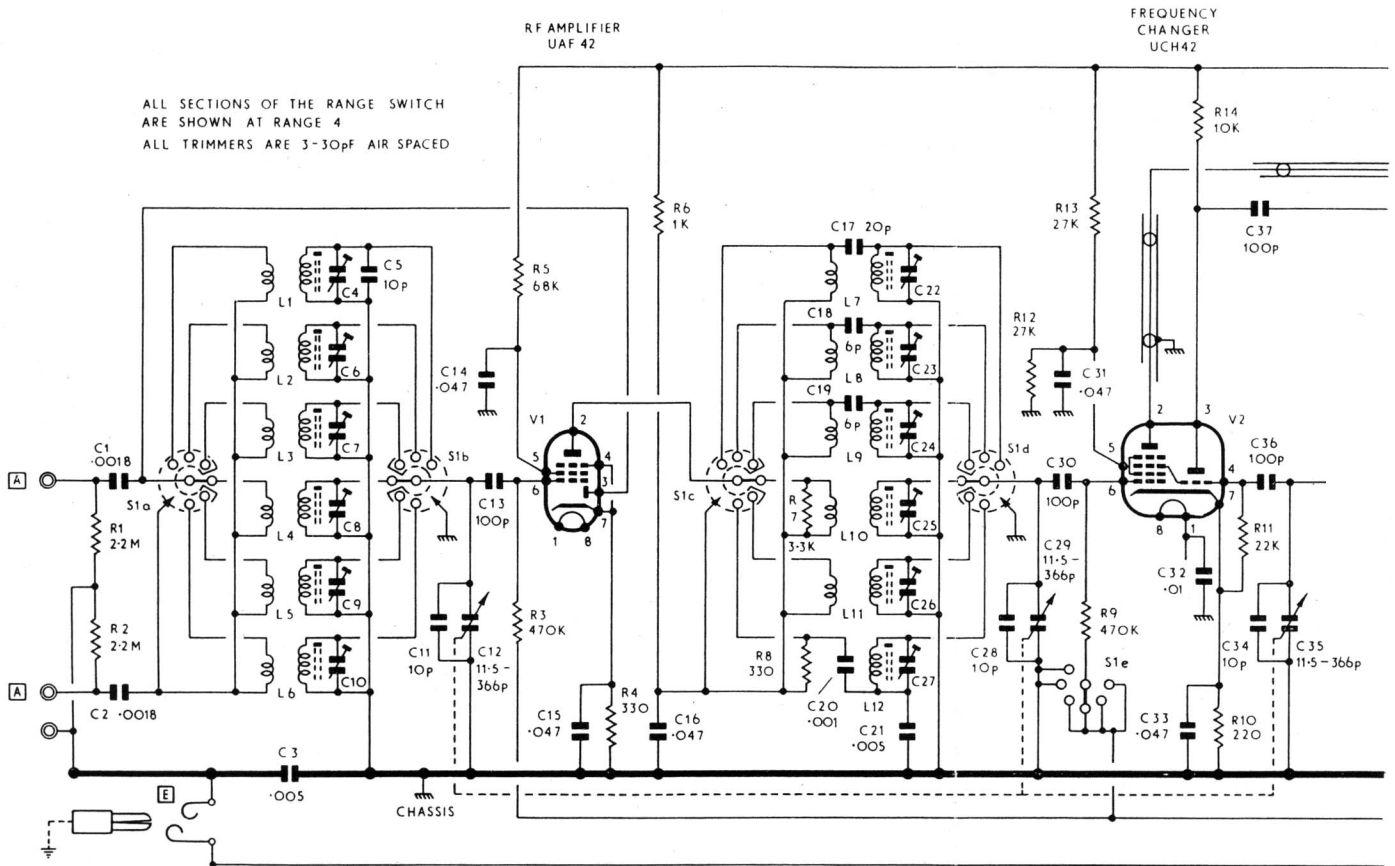

TABLE OF VOLTAGE VALUES

| Valve | Pin | 230V AC Input | | 110V AC Input | |
|-------|-----|-----------------|-----------------|-----------------|-----------------|
| | | 20K Ω /V | 600 Ω /V | 20K Ω /V | 600 Ω /V |
| V1 | 2 | 200V | 195V | 137V | 135V |
| | 5 | 102V | 90V | 70V | 60V |
| | 7 | 2.4V | 2.2V | 1.5V | 0.7V |
| V2 | 2 | 200V | 195V | 142V | 140V |
| | 3 | 148V | 130V | 90V | 70V |
| | 5 | 85V | 60V | 55V | 38V |
| V3 | 7 | 3.7V | 2.4V | 1.6V | 0.8V |
| | 2 | 200V | 195V | 137V | 135V |
| | 5 | 105V | 92V | 73V | 55V |
| V4 | 7 | 2.3V | 2.1V | 1.4V | 0.6V |
| | 8 | 102V | — | 32V | — |
| | 2 | 50V | 35V | 29V | 20V |
| V5 | 5 | 32V | 30V | 21V | 15V |
| | 7 | 1.3V | 1V | 0.9V | 0.2V |
| | 2 | 195V | 195V | 135V | 135V |
| V6 | 5 | 200V | 200V | 140V | 140V |
| | 7 | 13.7V | 13.5V | 9.5V | 9.2V |

All readings are DC taken between the point indicated and chassis. Range switch at Range 5. The readings are typical and a tolerance of 10% should be allowed. Two sets of readings are given, one for a meter having a sensitivity of 600 ohms per volt and the other 20,000 ohms per volt. When using meters of other sensitivities the tolerance should be increased accordingly.

SPARES

The following list gives the Ref. No's. of the major spares for the 670C receiver. Please quote the Serial No. of the set when ordering.

Coils

| | | | | | | | | |
|----|----|-------|-----|----|-------|-----|----|-------|
| L1 | .. | D3098 | L7 | .. | D3099 | L13 | .. | D3100 |
| L2 | .. | D3101 | L8 | .. | D3102 | L14 | .. | D3103 |
| L3 | .. | D3104 | L9 | .. | D3105 | L15 | .. | D3106 |
| L4 | .. | D3107 | L10 | .. | D3108 | L16 | .. | D3109 |
| L5 | .. | D3110 | L11 | .. | D3111 | L17 | .. | D3112 |
| L6 | .. | D3074 | L12 | .. | D3075 | L18 | .. | D3076 |

Chokes and Transformers

| | | | | | | |
|-------|----|----|----|----|----|--------|
| CH1/2 | .. | .. | .. | .. | .. | D2024 |
| CH3 | .. | .. | .. | .. | .. | 5863P |
| T1 | .. | .. | .. | .. | .. | D2511A |
| T2 | .. | .. | .. | .. | .. | D2511A |
| T3 | .. | .. | .. | .. | .. | 5880P |

Miscellaneous

| | | | | | | |
|-------------------|----|----|----|----|----|--------|
| Loudspeaker | .. | .. | .. | .. | .. | 6245P |
| Ballast Resistor | .. | .. | .. | .. | .. | 4825PA |
| Thermistor | .. | .. | .. | .. | .. | 6454P |
| Fuses (500mA) | .. | .. | .. | .. | .. | 6244P |
| Window Glass | .. | .. | .. | .. | .. | 5847P |
| RV1 (Volume) | .. | .. | .. | .. | .. | 4103PB |
| RV2 (Tone/on-off) | .. | .. | .. | .. | .. | 4102PB |

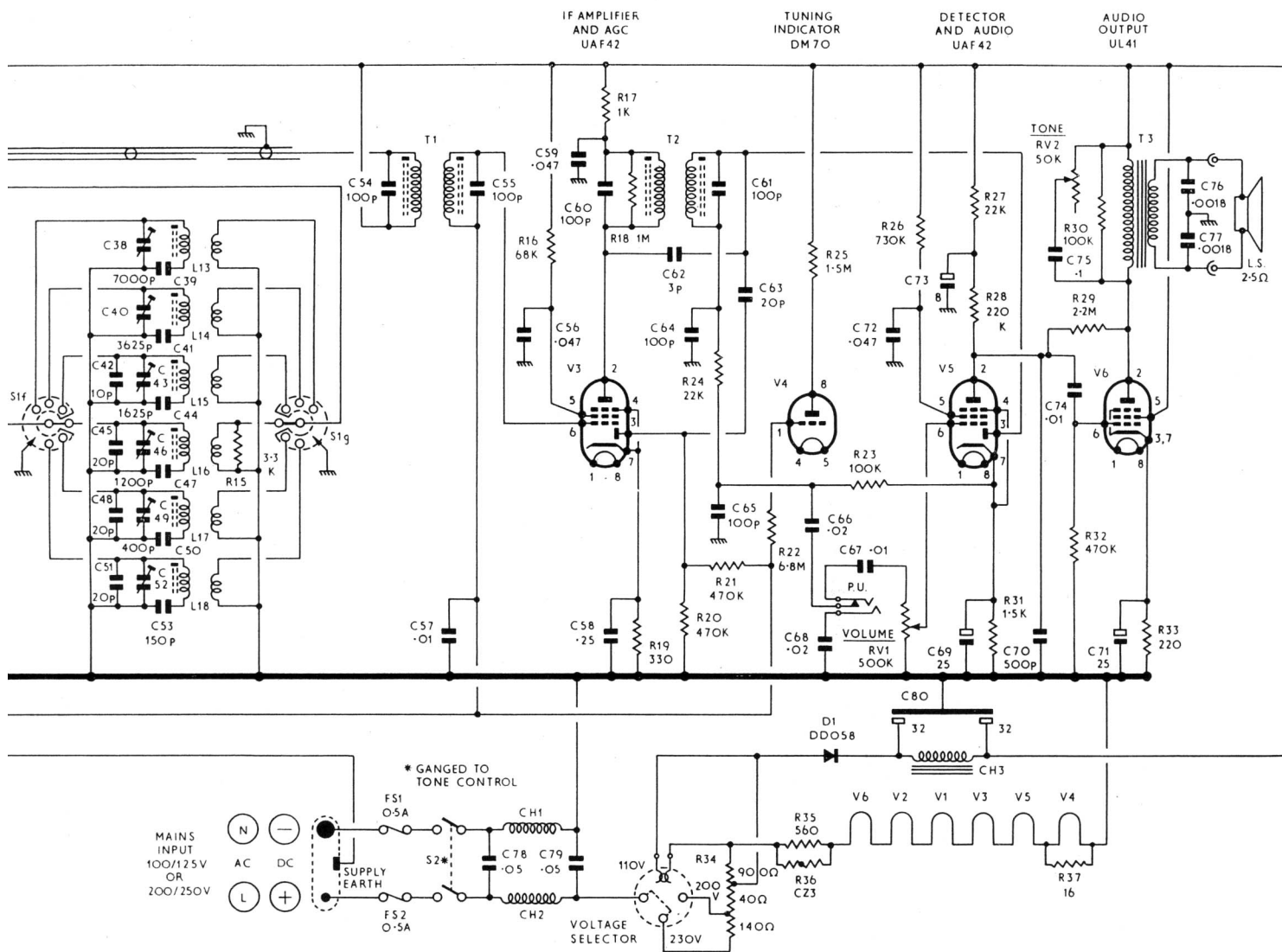

LIST OF COMPONENT VALUES

Capacitors

- C1, 2, 76, 77: 0.0018 μ F Disc Ceramic +80% -20% 1250V.
 C3: 0.005 μ F Disc Ceramic +80% -20% 900V.
 C4, 6-10, 22-27, 38, 40, 43, 46, 49, 52: 3-30pF Air Trimmer.
 C5, 42: 10pF Silvered Mica 10% 350V.
 C11, 28, 34: 10pF Tubular Ceramic 10% 750V.
 C12, 29, 35: 11.5-366pF, 3-gang variable.
 C13, 30: 100pF Silvered Mica 10% 350V.
 C14-16, 31, 33, 56, 59, 72: 0.047 μ F Polyester 10% 400V.
 C17, 63: 20pF Tubular Ceramic 10% 750V.
 C18, 19: 6pF Tubular Ceramic 10% 750V.
 C20: 0.001 μ F Tubular Ceramic 10% 750V.
 C21: 0.005 μ F Tubular Ceramic 20% 750V.
 C32, 57: 0.01 μ F Metallised Paper 20% 150V.
 C36, 37, 64, 65: 100pF Tubular Ceramic 10% 750V.
 C39: 0.007 μ F Polystyrene 1% 125V.
 C41: 3625pF Silvered Mica 1% 350V.
 C44: 1625pF Silvered Mica 1% 350V.
 C45, 48, 51: 20pF Silvered Mica 10% 350V.
 C47: 1200pF Silvered Mica 1% 350V.
 C50: 400pF Silvered Mica 1% 350V.
 C53: 150pF Silvered Mica 1% 350V.
 C54, 55, 60, 61: 100pF Silvered Mica 2% 350V.
 C58: 0.25 μ F Metallised Paper 20% 150V.
 C62: 3 pF Tubular Ceramic \pm 0.5pF 750V.
 C66, 68: 0.02 μ F Plate Ceramic 25% 1500V.
 C67, 74: 0.01 μ F Tubular Ceramic +80% -20% 350V.
 C69, 71: 25 μ F Tubular Electrolytic +100% -20% 25V.
 C70: 500pF Moulded Mica 20% 350V.
 C73: 8 μ F Tubular Electrolytic +100% -20% 275V.
 C75: 0.1 μ F Metallised Paper 20% 600V.
 C78, 79: 0.05 μ F Metallised Paper 20% 500V.
 C80: 32 μ F + 32 μ F Tubular Electrolytic +50% -20% 350V.

Resistors

- R1, 2, 29: 2.2M Ω 10% $\frac{1}{2}$ watt.
 R3, 9, 20, 21, 32: 0.47M Ω 10% $\frac{1}{2}$ watt.
 R4, 8, 19: 330 Ω 10% $\frac{1}{2}$ watt.
 R5, 16: 68,000 Ω 10% $\frac{1}{2}$ watt.
 R6, 17: 1,000 Ω 10% $\frac{1}{2}$ watt.
 R7, 15: 3,300 Ω 10% $\frac{1}{2}$ watt.
 R10, 33: 220 Ω 10% $\frac{1}{2}$ watt.
 R11, 24, 27: 22,000 Ω 10% $\frac{1}{2}$ watt.
 R12, 13: 27,000 Ω 10% 1 watt.
 R14: 10,000 Ω 10% $\frac{1}{2}$ watt.
 R18: 1M Ω 10% $\frac{1}{2}$ watt.
 R22: 6.8M Ω 10% $\frac{1}{2}$ watt.
 R23: 0.1M Ω 10% $\frac{1}{2}$ watt.
 R25: 1.5M Ω 10% $\frac{1}{2}$ watt.
 R26: 0.73M Ω 10% $\frac{1}{2}$ watt.
 R28: 0.22M Ω 10% $\frac{1}{2}$ watt.
 R30: 0.1M Ω 10% 1 watt.
 R31: 1,500 Ω 10% $\frac{1}{2}$ watt.
 R34: 1080 Ω wirewound, tapped at 140 and 180 Ω , 0.15A.
 R35: 560 Ω wirewound, 5% 6 watt.
 R36: CZ3 Thermistor.
 R37: 16 Ω wirewound, 10% 3 watt.
 RV1: 0.5M Ω .
 RV2: 50,000 Ω with d.p. switch.

LIST OF VALVE TYPES

- | | | | | |
|----|----|-------|----|-----------------------------|
| V1 | .. | UAF42 | .. | RF Amplifier. |
| V2 | .. | UCH42 | .. | Frequency Changer. |
| V3 | .. | UAF42 | .. | IF Amplifier/AGC Rectifier. |
| V4 | .. | DM70 | .. | Tuning Indicator. |
| V5 | .. | UAF42 | .. | Detector/AF Amplifier. |
| V6 | .. | UL41 | .. | Audio Output. |
| D1 | .. | DD058 | .. | HT Rectifier. |